

Analyzing the Impact of Impulsive Noise on spectrum sensing Techniques for Cognitive Radio Networks

Dipak Patil¹, Manoj Bhalerao², Vishal Wankhede³, Vijay Birari⁴, Rana Mahajan⁵, Vinod Khairnar⁶

Submitted: 25/05/2023

Revised: 05/07/2023

Accepted: 24/07/2023

Abstract: The widespread adoption of cognitive radio networks (CRNs) has led to increased interest in “spectrum sensing” techniques to efficiently detect and utilize underutilized frequency bands. However, the presence of impulsive noise poses a significant challenge to accurate “spectrum sensing”, as it can disrupt signal measurements and lead to false detections. This research paper aims to analyze the impact of impulsive noise on “spectrum sensing” techniques for CRNs. Impulsive noise is a type of noise that occurs randomly and can significantly affect the performance of cognitive radio systems. The assessment involves comparing the performance of different “spectrum sensing” techniques such as Energy detection (ED), Maximum-minimum eigenvalue detection (MMED), and Generalized Likelihood Ratio Test (GLRT) in the presence of impulsive noise. The analysis is done by considering different metrics and optimum “spectrum sensing” model is proposed. This proposed work involves the use of a direct conversion receiver architecture with automatic gain control (AGC) to minimize noise and DC offset. The simulation scenarios involve different threshold and signal-to-noise ratio (SNR) levels to evaluate the performance of different “spectrum sensing” techniques in the presence of impulsive noise. The comparative evaluation is done by analyzing the graphical results obtained from the simulations and from results it is evident that the GLRT detection method exhibits better sensing ability in an impulsive.

Keywords: Automatic Gain Control. Cognitive radio Networks. Energy detection. GLRT, “spectrum sensing”.

I. Introduction

With reference to the increasing demand for wireless communication services, the availability of the frequency spectrum has become a major issue. The allocation of this spectrum has become a challenge for policymakers, as they must balance the needs of various stakeholders, including government agencies, commercial providers, and individual users.

The current spectrum allocation policies are often inflexible and do not account for changes in technology or usage patterns. This has led to inefficiencies in spectrum utilization and a lack of available spectrum in certain regions or for certain applications. These rules are drawn from a model that is considered to be static. In this model, the distribution of the spectrum is governed by a variety of governmental bodies all over the world, such as the Federal Communication Commission (FCC). It results in an inefficient use of the available frequency spectrum and a frittering away of valuable frequency resources [1]. The

Dynamics of Spectrum Management has introduced techniques for improving the utilization of existing spectrum allocations. The cognitive radio (CR) has come forward as an intelligent system to exploit the available spectrum and has proven as the supreme solution to defeating the spectrum scarcity crisis. Auxiliary spectrum efficiency can be obtained by expanding the CR networks (CRN) to support the new wireless users in the accessible packed spectrum without causing any trouble to the existing licensed primary users (PU) performance [2]. The CRN permits the unlicensed secondary users (SU) also referred to as CR users, to share the wireless channels with the PU in an opportunistic approach. Still there exists the challenge to the CR users with the instability within the accessible spectrum and assorted Quality of Service(QoS) necessities. “spectrum sensing” is considered the major necessity for the realization of a CRN. It permits to use of the spectrum segment in the radio environment by repetitively examining the vacant spectrum and detecting the PUs to avoid interference. It has been determined that cooperative “spectrum sensing” is the most effective method because of its capacity to resolve hidden PU. [3]. The eigenvalue-based “spectrum sensing” techniques have shown the best performance of the existing sensing methods [4-6].

The performance of the “spectrum sensing” methods is tested over the Impulsive noise (IN) background[7-8]. The basis of IN generation includes electromagnetic interference, including, sea wave reflections, lightning, noise from running vehicles, etc. An effect of IN over “spectrum

¹Dipak Patil is with Sandip Institute of Engineering and Management, Nashik Maharashtra, India E-mail: dipakpatil25@gmail.com

²Manoj Bhalerao is with PVG's College of Engineering, Nashik, Maharashtra, India E-mail: hod_etc@pvgcoenashik.org

³Vishal Wankhede is with S H H J B Polytechnic, Chandwad Maharashtra, India E-mail: wankhede@pvgcoenashik.org

⁴Vijay Birari is with KBGT College of Engineering, Nashik, Maharashtra, India E-mail: vijaybirari@yahoo.com

⁵Rana Mahajan is with SVIT, Nashik, Maharashtra, India E-mail: rana.entc@gmail.com

⁶Vinod Khairnar is with METs IOE, Nashik. E-mail: khairnar.vinod@gmail.com

sensing” in fading and non-fading conditions is considered for analysis by using the GLRT method of detection [9].

This paper contributes to an integrated investigation of the cause of IN on the performance of detection techniques namely, ED, MMED, and GLRT. The performance analysis is based on the effect of IN with the inclusion of AGC in residual dynamic DC offset. The comparative performance assessment is done for the P-model with C- the model and R-model. The P-model offered better sensing results and more precise sensing results are obtained even in the presence of IN.

The remaining sections of the work are structured in the same manner as is demonstrated in the paragraphs that follow. In the section that comes after this one, which is titled "Section 2," the specifics of the system model are broken down into agonising depth. In the section that follows, titled "Section 3," you will find an explanation of the simulation setup that will be used to compare the performance of three distinct "spectrum sensing" approaches, as well as the configuration of the parameters. This comparison will be carried out using the information that you will find in the following section, titled "Section 3." In Section 4, the results of the simulations are illustrated, along with a comprehensive analysis and a comparison of the sensing performance. The last and most recent section of the publication, which bears the number 5, is devoted to an analysis of the results of the simulation.

II. System model

The model of the system is constructed such that it may address the problem of “spectrum sensing”. The test of the binary hypothesis distinguished between the hypotheses H_0 and H_1 , which respectively reflect the sensed states of signal presence and signal absence. It is possible to determine the relevant values for the detection probability (P_d) and the “false alarm probability” (P_{fa}) using the formula [13].

$$P_d = P(T > \gamma/H_1) \quad (1)$$

$$P_{fa} = P(T > \gamma/H_0) \quad (2)$$

The receiver operating characteristic (ROC) is the graph of P_d versus P_{fa} which varies with the “decision threshold” γ . detection-dependent test statistics is denoted by T . The “spectrum sensing” requirements are considered for choosing the value of γ , and the threshold is estimated through ROC.

For analysis purposes, multiple antennas are activated by the SU to detect the primary signal. The channel is assumed constant and memoryless in all the sensing windows and constant throughout the detection time.

m denotes antennas in a CR considered for the analysis purpose. This is collecting n “baseband complex” (I/Q) samples of the received signal from p “primary transmitters”

throughout the sensing period. All the received samples are arranged in a matrix $Y \in C^{m \times n}$. Another matrix $X \in C^{p \times n}$ is used to arrange the y . The transmitted signal samples transmitted from the p transmitters channel matrix $H \in C^{m \times p}$ with the elements $\{h_{ij}\}, i = 1, 2, \dots, m$ and $j = 1, 2, \dots, p$, relate to the channel gains are amongst the j^{th} primary transmitter and i^{th} receiver.

Additional two matrices namely, V and $V_{IN} \in C^{m \times n}$ are used to exemplify thermal noise and impulsive noise samples. Based on this then the matrix of received samples is represented as,

$$Y = \begin{cases} HX + V + V_{IN} & H_1 \\ V & H_0 \end{cases} \quad (3)$$

m Complex Gaussian noise samples are collected for the received signal under H_0 vector with “zero mean” and “variance” σ_v^2 . Then the received vector contains signal plus noise under H_1 compare to H_0 .

The transmitted signal sample is denoted X , which represents a Gaussian2 random variable with zero mean and variance σ_s^2 .

The signal vector matrix $X \triangleq [x(1) \dots x(N)]$ is $1 \times n$ is and $V \triangleq [v(1) \dots v(N)]$ is $m \times n$ noise matrix.

Considering that the PUs symbols are unknown, with assumptions s is circularly symmetric Gaussian-distributed with zero mean and covariance matrix $R_s = hh^\dagger$, where, \dagger indicates complex conjugate and transpose.

Under H_1 , the SNR at the receiver is defined as,

$$\rho \triangleq \frac{E\|HX\|^2}{E\|V\|^2} = \frac{\sigma_s^2 \|h\|^2}{\sigma_v^2 m} \quad (4)$$

where, $\|\cdot\|$ denotes Euclidean (L2) norm.

The received $m \times n$ matrix is used to store the received samples,

$$Y \triangleq [y(1) \dots \dots y(N)] \quad (5)$$

When performing eigenvalue-based “spectrum sensing”, it is necessary to describe spectral holes using test statistics, and these statistics are dependent on the eigenvalues of the sample covariance matrix of the received signal matrix Y . According to the description, “the sample covariance matrix R for centralized data fusion cooperative sensing looks like this”:

$$R \triangleq \frac{1}{N} YY^\dagger \quad (6)$$

Let $\lambda_1 \geq \dots \geq \lambda_K$ = “eigenvalues of R sorted in decreasing order assuming the only primary transmitter”.

When centralized cooperative sensing is used with CRs that only have a single antenna, the matrix Y is meant to be available at the FC as though no signal processing is necessary before each row of Y_{is} is sent to the FC.

After modifications in the direct conversion radio receiver [14], the received signal covariance matrix becomes,

$$R' \cong \frac{1}{N} Y' Y^\dagger = \frac{1}{N} G Y^\dagger = G R G \quad (7)$$

where G = “diagonal AGC gain matrix”.

Snubbing the constants without performing any signal processing operations in addition to AGC, G becomes,

$$G_{ii} = (y_i \dagger y_i)^{-0.5} = \|y_i\|_2^{-1} \quad (8)$$

where, y_i = “ i^{th} row of Y , i.e., the set of n samples collected by the i^{th} CR, and $\|y_i\|_2$ is the Euclidean norm of y_i ”.

For performance analysis, the different cases of IN are considered for demonstrating the impact of IN on “spectrum sensing”.

The test figures considered for “GLRT, MMED, and ED” according to [4, 15,16] are,

$$T_{GLRT} = \frac{\lambda_1}{\frac{1}{m} \text{tr}(R)} = \frac{\lambda_1}{\frac{1}{m} \sum_{i=1}^m \lambda_i} \quad (9)$$

$$T_{MMED} = \frac{\lambda_1}{\lambda_m} \quad (10)$$

$$T_{ED} = \frac{\|Y\|_F^2}{mn\sigma^2} = \frac{1}{m\sigma^2} \sum_{i=1}^m \lambda_i \quad (11)$$

In the above test statistics, the “thermal noise power” is represented by σ^2 in addition to this, $\text{tr}(R)$ and $\|Y\|_F$ are the trace and the Fresenius norm of the fundamental matrix respectively. When there is noise present, methods that are based on eigenvalues make the assumption that the covariance matrix is a diagonal matrix with its elements equal to 2; this is the case even though this is not always the case. In addition, if the environment contains only Gaussian noise, the test statistic for each and every one of the sensing methods that are being evaluated should be equal to one. This is the case even if there is only Gaussian noise in the environment.

Following models are considered for performance comparison of different “spectrum sensing” techniques:

2.1 Conventional “discrete-time memoryless linear MIMO fading channel model” (C-Model)

In the beginning, the traditional “discrete-time memory-less MIMO fading channel model” is developed so that an evaluation of the performance of various “spectrum sensing” approaches can take place. This model is static with single-sensor centralized cooperative sensing. The Additive White Gaussian Noise (AWGN) channel is assigned. In this model, no random process and signal processing is involved. It is projected that the sensing performance beneath the conventional model can be rather

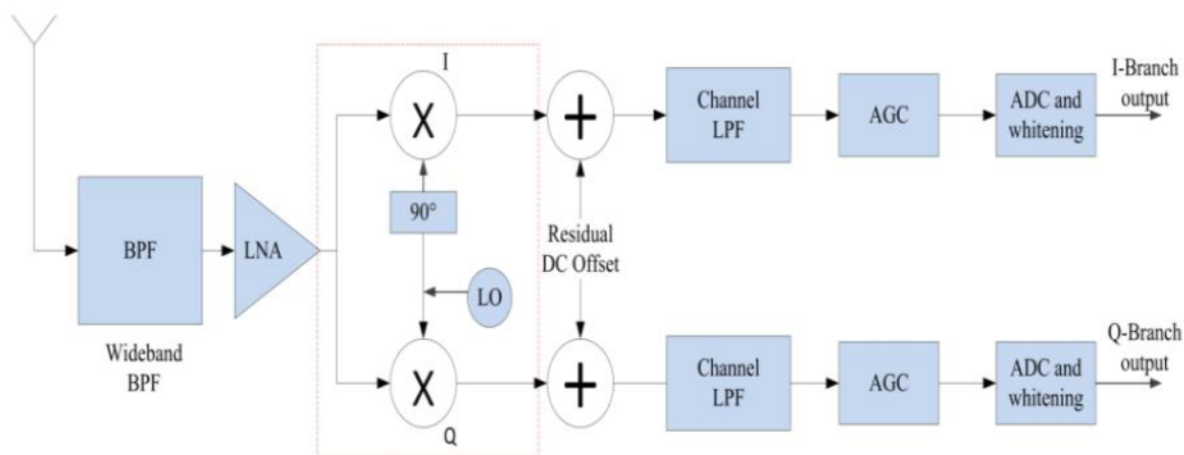

Fig.1. CR Receiver diagram

Within the framework of the direct-conversion CR receiver architecture, which is depicted in Figure 1, the R-model implements fundamental signal processing operations like as “filtering, quantization, and automatic gain control” (AGC). The direct-conversion receiver (DCR) is implemented for cognitive radio applications in regular circumstances. Fig. 1 is used as the key reference to build this model. Previous work in [9], illustrates the discovery of samples affected by IN. These samples are considered for analysis on “spectrum sensing” techniques and have shown noticeable improvement in the effect of IN. The model presented in [10-12] is used for performance comparison in which the IN waveform is produced by receiving the white noise signal as shown in Fig.2. Table 1, denotes the parameters configured for “spectrum sensing” as per the type of the noise source. suspicious if IN is present, while it can be better when the IN is not present.

2.2 The Realistic Implementation Oriented MIMO model (R-Model)

The realistic implementation orientation model is based on a random process. This model is dynamic and it is implemented by considering the signal detection in CRNs for multi-sensory detection situations for different IN levels. In this model slowly time-varying Rayleigh fading channel is considered

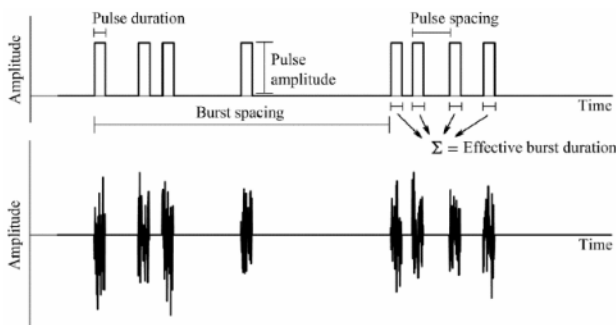

Fig. 2. Waveform for Impulsive Noise.

2.3 Performance orientation model (P-Model)

Fig.1 is used as the main reference to build the P- model. The existence and non-existence of IN is the point of reference used for the adaptation of the threshold levels set for the different sensing techniques. Analytical investigations under this model are used as contributions to the performance comparison of different detection techniques in the context of “spectrum sensing”. The P-model is also dynamic and is implemented for the centralized data fusion cooperative “spectrum sensing” in multi-spectrum/multi-sensor scenarios. The detection process is carried out by the Maximum Likelihood Estimator (MLE) in the time-varying Rayleigh fading channel.

III. Simulation Setup

The simulation setup is developed allowing for the general centralized data-fusion cooperative “spectrum sensing” situation. For C- the model initial assumption is made that the received signal samples with the matrix Y in equation (1), are available to the FC. In this model, the sample values are sent to the FC directly without any signal processing by CR. Matrices X , H , V and V_{IN} under the C-model are generated as follows:

X = “produced by zero-mean complex Gaussian samples”.

H = “The elements in the channel matrix H are zero mean”.

V = “Complex Gaussian variables for the additive thermal noise and the impulse noise”.

V_{IN} = “Complex Gaussian variables the impulse noise”.

Both V and V_{IN} are corrupting the received samples

For the R and P-model, the simulation setup is built concerning receiver architecture shown in Fig.1.

Matrices “ $X, H, V,$ and V_{IN} ” under the R and P -model are generated as follows:

X : is formed by a simple signal processing operation of filtering with a length- L due average (MA) filter without quantization. H, V and V_{IN} are modeled similar to that of the C- model.

The influence of the Low Noise Amplifier (LNA) and the AGC on the samples processed by the i^{th} CR, $i = 1, 2, \dots, m$ is given by the gain.

$$g_i = \frac{f_{od} D \sqrt{2}}{6 \sqrt{\frac{1}{n} y_i + y_i}} = \frac{f_{od} D \sqrt{2}}{6 \|y_i\|_2} \quad (12)$$

where, y_i is i^{th} row of Y , and $\|y_i\|_2$ is the Euclidean norm of y_i . The static performance of the amplified samples of y_i is changes because of AGC. According to this, it is imagined the gains in equation (12) are taken into account for the sensing techniques that insist on knowledge of the noise variance information in the derivation of new test statistics.

With reference architecture shown in Fig.1, the simulation setup is built to stick to the overall centralized data-fusion cooperative “spectrum sensing” scenario.

Table 1. Parameters configured for simulation of sensing model

Parameters Defined	Description
m	“Antennas in CR / CR with one antenna each”
n	“Number of received samples from the primary transmitter”

N_e	“The number of Monte Carlo simulation events”
N_q	“The number of quantization levels” .
D	“ADC dynamic range”
f_{od}	“Overdrive factor”
For Impulsive Noise additional parameters to be set	
p_{IN}	“Probability of IN occurrence”
p_{CR}	“Fractions of CR hits by IN”.
N_S	“Number of IN blurs”
K	“The ratio of avg. IN power and avg. thermal noise power”
β	“The average number of samples between IN pulses”
A	“The mean of the log-normal IN amplitudes”.
B	“The standard deviation of the log-normal amplitudes”

IV. Simulation Results

In this section, initially, the extensive simulations are performed by setting the different threshold and SNR levels to compare the performance of all the models i.e. C-model, R-model, and P-model for variable scenarios. Later ROC curves are depicted for performance analysis of r all the detection techniques.

The performance measurements parameters set for simulation scenario one as, $m = 8$, $n = 50$, $SNR = -10$ dB, $N_e = 2000$, along with this, the minimum to maximum threshold levels sets in the range of are $\gamma = 0.78$ to $\gamma = 1.1$ with , 8 different threshold events. Fig.3. presents comparison plot for, P_d and P_{fa} with respect to the changes in threshold levels for all three models. For fixed threshold, the behavior of P_{fa} is shown, and it is evident from the results that P_d is improved for all the models for variable threshold levels. These curves can be used to compute the threshold necessary to achieve a given false alarm rate.

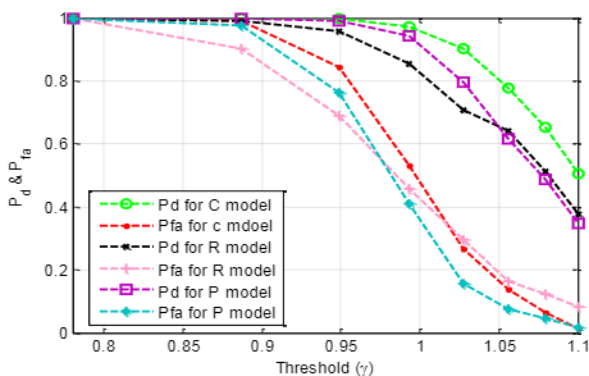

Fig. 3. Pd, Pfa Vs Threshold

The second simulation scenario involves changing the signal-to-noise ratio (SNR) while maintaining the threshold level at value = 1.4. The range of possible SNR values is from -20 dB to 10 dB. Figure 4 displays the outcomes of the simulation in the form of a graph between P_d and P_{fa} for a variety of SNR values.

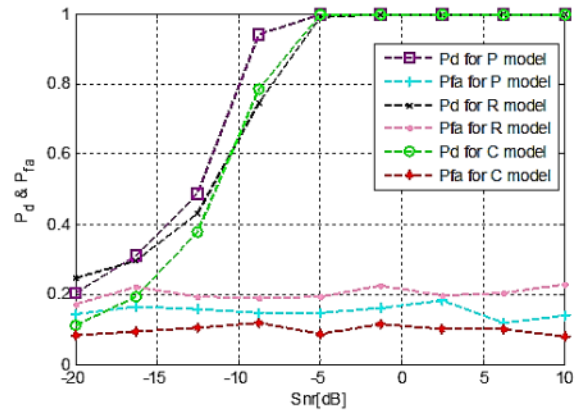

Fig 4. Comparison of Pd, Pfa Vs SNR

It can be observed from the results that, with an increase in SNR P_d is increased. Further significant improvement in P_d is obtained. For a wide range of SNR situations, the P-model consistently produces superior results to those of the C-model and the R-model. Although Fig.3-4 only shows data for the ED approach, it is generally accepted that the findings are applicable to all three of the detection methods that are being taken into account for the analysis.

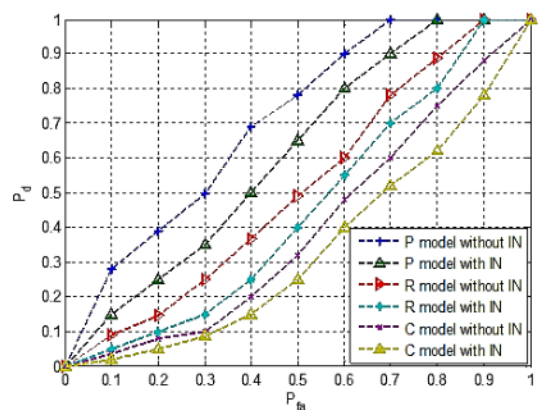

Fig.5. ROC curve for ED method with $m=8$, $SNR = -10$ dB.

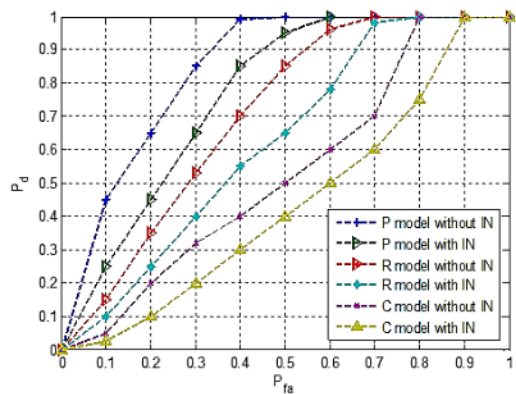

Fig. 6. ROC curve for GLRT method with $m=8$, $SNR = -10$ dB.

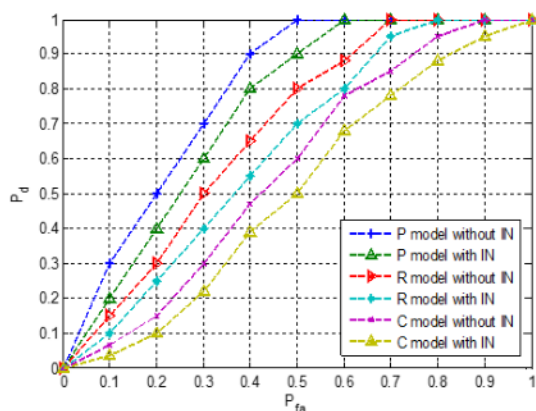

Fig. 7. ROC curve for MMED method with $m=8$, $SNR = -10$ dB

The ROC curve for all of the “spectrum sensing” methods that were evaluated may be seen in Fig. 5-7, along with the effect of IN. The findings provide an illustration of the performance of the system in IN situations. The parameters set for simulation are $p_{IN} = 0.2$, $K = 10$, $p_{CR} = 0.5$, $N_s = 10$, $N_b = 1$ with $A = 100$, $B = 75$ and $\beta = 10$. In both the R and the P-model, the threshold levels that are established for performance evaluation with and without IN are the same. It has been observed, based on the ROC curves, that the sensing performance can be too positive if the C-model operates without IN, and it can be too negative with IN for all detection techniques. Both of these outcomes are possible. And the results show that including IN lowers performance across the board for all false alarm probability values when considering C- the model. When compared to the other models, the R-model shows a significantly smaller level of influence of IN on the sensing. In addition, it is clear from the findings that both the sensing results with IN and those without IN are extremely near to one another when it comes to the R and P-model. This can be deduced from the findings.

V. Conclusion

The AGC-based model is suggested and implemented in this research for the purpose of performance evaluation of three

distinct detection approaches for spectrum detection in cognitive radio networks under a variety of IN situations. The performance of the proposed model is compared with the conventional models and exhibited better sensing results. GLRT detection method demonstrated significant improvement over ED and MMED methods for “spectrum sensing” even in presence of IN background. In addition, it has been reached the conclusion that the accuracy of sensing in the implementation-oriented model could have been irregular in comparison to the typical residual dynamic DC-offsets. The precise design of RF and DC offset compensation circuits is one way in which it is possible to make improvements.

References

- [1] Federal Communications Commission.: Spectrum policy task force report, ET Docket No. 02-135, (2002)
- [2] Mitola, J., Maguire, and G.Q.: Cognitive Radio: making software radios more personal. *IEEE Personal Commu.Mag.*, Vol.6, Issue 4, pp. 13–18 (1999)
- [3] Akyildiz, I.F.:Cooperative “spectrum sensing” in cognitive radio networks: A survey: a survey. In: Elsevier physical communication, pp.40-62 (2011).
- [4] Nadler, B., Garelo, R.: Performance of Eigenvalue-Based Signal Detectors with Known and Unknown Noise Level. In *Proceedings of IEEE International Conference on Communications, ICC, Kyoto, Japan*, pp.1-5 (2011)
- [5] Kortun, A., Ratnarajah, T., Sellathurai, M., Zhong, C., Papadias, C.: On the performance of eigenvalue-based cooperative “spectrum sensing” for cognitive radio. *IEEE Journal on Sel. Top. Signal Processing*, 49–55 (2011)
- [6] Tandra, R., Sahai, A.: Fundamental limits on detection in low SNR under noise uncertainty: in *Proc. Int. Conf. Wireless Networks., Communications.Mobile Computing., Maui, HI*, pp. 464–469 (2005)
- [7] Osorio, M-R., de Haro-Ariet, Calvo-Ramon, L., Sanchez L.M.: Performance evaluation of W-CDMA in actual impulsive noise scenarios using adaptive antennas. *IEEE Proc. Communications*, 151, pp. 589–594 (2004)
- [8] Budsabathon, M., Hara, S.: Robustness of OFDM Signal Against Temporally Localized Impulsive Noise. In *Proceedings of the IEEE VTS 54th Vehicular Technology Conference, VTC 2001*, 7–11; Vol. 3, pp. 1672–1676 (2001)
- [9] Kang, H.G., Song, I., Yoon, S., Kim, Y.H.: A class of spectrum-sensing schemes for cognitive radio under impulsive noise circumstances: Structure and performance in nonfading and fading environments. *IEEE Trans. Veh. Tech.*, pp. 4322–4339(2010)

- [10] Guimarães, D.A., de Souza, R.A., dos Anjos.: Implementation orientation model for centralized data fusion cooperative spectrum. *IEEE Commun. letter* 16, pp.184-187, (2012)
- [11] Guimarães, D.A., de Souza, R.A., Barreto, A.N.: Performance of Cooperative Eigenvalue" spectrum sensing" with a Realistic Receiver Model under Impulsive Noise. *Journal of Sensor and Actuator Networks*, pp.46-59(2012)
- [12] Lago, J., Fernández, Salter, J.: Modeling Impulsive Interference in DVB-T: Statistical Analysis, Test Waveforms, and Receiver Performance. BBC R&D white paper WHP 080 (2004)
- [13] Yates, R.D., Goodman D.: Probability, and Stochastic Processes: A Friendly Introduction for Electrical and Computer Engineers. 2nd ed. (2004)
- [14] Razavi, B.: Design considerations for direct-conversion receivers. *IEEE Trans. Circuits Syst. II*, vol. 44, no. 6, pp. 428–43 (1997)
- [15] Dipak P. Patil , Vijay M. Wadhai, "Performance Evaluation of "spectrum sensing" in Cognitive Radio for Conventional Discrete-time Memoryless MIMO Fading Channel Model," in proceedings of IEEE International Conference on Collaborative Computing: Networking, Applications and Work sharing, at Miami Florida USA, pp. 425-430, Oct. 2014 .978-1-63190-043-3 © 2014 ICST.
- [16] Dipak P. Patil and Vijay M. Wadhai, "Performance Evaluation in Cognitive Radio Network over Wireless Fading Channels from "spectrum sensing" Perspective," in proceedings of IEEE International Conference on Green Computing, Communications and Conservation of Energy, IEEE ICGCE-2013, at Kavaraipeetai, Chennai, pp 53-58, Dec. 2013.978-1-4673-6126-2/13/\$31.00 © 2013 IEEE.
- [17] Ms. Elena Rosemaro. (2014). An Experimental Analysis Of Dependency On Automation And Management Skills. *International Journal of New Practices in Management and Engineering*, 3(01), 01 - 06. Retrieved from <http://ijnpm.org/index.php/IJNPME/article/view/25>
- [18] Vijayalakshmi, V., & Sharmila, K. (2023). Secure Data Transactions based on Hash Coded Starvation Blockchain Security using Padded Ring Signature-ECC for Network of Things. *International Journal on Recent and Innovation Trends in Computing and Communication*, 11(1), 53–61. <https://doi.org/10.17762/ijritcc.v11i1.5986>
- [19] Aoudni, Y., Donald, C., Farouk, A., Sahay, K. B., Babu, D. V., Tripathi, V., & Dhabliya, D. (2022). loud security based attack detection using transductive learning integrated with hidden markov model. *Pattern Recognition Letters*, 157, 16-26. doi:10.1016/j.patrec.2022.02.012